

STEREO RECEIVER R-50

SERVICE MANUAL

FRONT PANEL

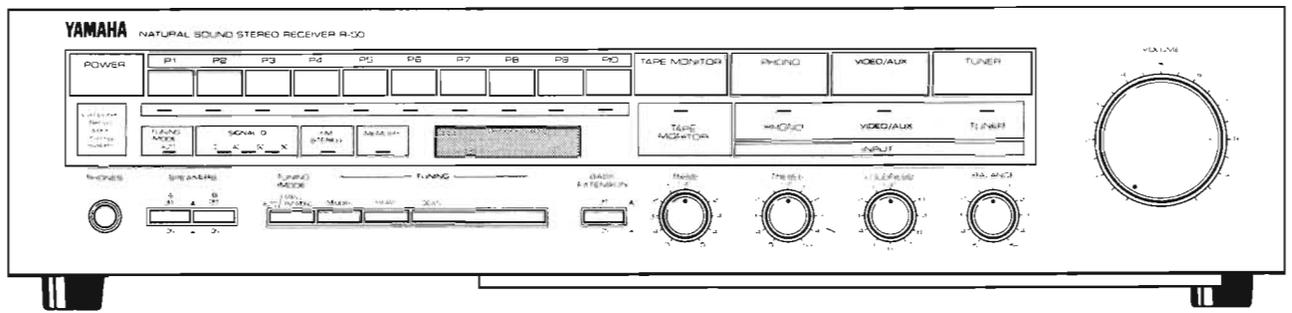

CONTENTS

TO SERVICE PERSONNEL	1
SPECIFICATIONS	1
REAR PANEL	2
INTERNAL VIEW	3
DISASSEMBLY PROCEDURES	3
ADJUSTMENTS	4 ~ 6
PRINTED CIRCUIT BOARD	7, 8
SCHEMATIC DIAGRAM	9
BLOCK DIAGRAM	9
PARTS LIST	10 ~ 19



TO SERVICE PERSONNEL

(Prepared in accordance with UL Standard 1270)

Before service of this appliance by you, please carefully read this service manual.

Please make Leakage-current or Resistance measurements by suitable meter to determine that exposed parts are acceptably insulated from the supply circuit before returning the appliance to the customer.

- A PROBE WITH SHIELDED LEAD.
- B SEPARATED AND USED AS CLIP WHEN MEASURING CURRENTS FROM ONE PART OF APPLIANCE TO ANOTHER.

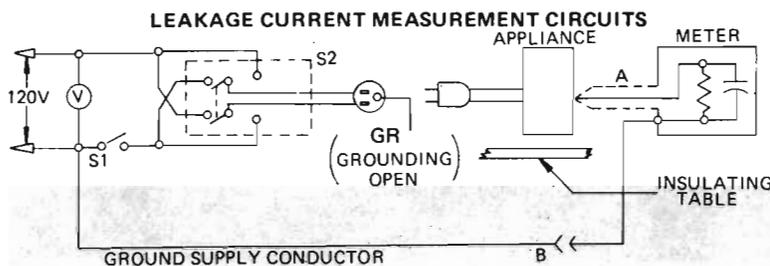

Appliance intended for connection to a 120 volt power supply.

Confirm that the leakage current is not more than 0.5mA AC.

SPECIFICATIONS

AUDIO SECTION

Continuous Power Per Channel	
20Hz to 20kHz 0.015% THD 8Ω	35W
Dynamic Power	
1kHz IHF Signal 4Ω	60W
2Ω	70W
DIN Standard Output Power Per Channel	
1kHz 1% THD 8Ω	45W (A)(B)(G)
Dynamic Headroom (IHF)	
8Ω	1.8dB
Power Band Width	
0.02% THD 17.5W 8Ω	10Hz to 30kHz
Damping Factor	
1kHz 8Ω	49
Input Sensitivity/Impedance	
Phono	2.5mV/47kΩ
Aux, Tape	120mV/42kΩ
Input Sensitivity (New IHF)	
Phono	0.42mV
Aux, Tape	20mV
Maximum Input Signal	
1kHz 0.01% THD Phono	85mV
Output Level/Impedance	
Rec Out	120mV/1kΩ
Headphone Jack Rated Output/Impedance	
0.015% THD	0.59V/220Ω
Frequency Response	
20Hz to 100kHz Aux, Tape	-3dB
RIAA Equalization Deviation	
Phono	±0.5dB
Total Harmonic Distortion	
Phono (IV)	0.015%
Aux, Tape to SP Out 1W/8Ω	0.008%
Intermodulation Distortion	
Aux, Tape Rated Output/8Ω	0.01%
Intermodulation Distortion (DIN)	
Aux, Tape 8Ω	0.01% (A)(B)(G)
Signal to Noise Ratio (IHF-A-Network)	
Phono (5mV Input Shorted)	88dB/80dB (G)
Aux, Tape, Tuner (Input Shorted)	97dB/95dB (G)
Signal to Noise Ratio (New IHF)	
Phono	73dB/72dB (G)
Aux, Tape, Tuner	79dB
Residual Noise (IHF-A-Network)	
	175μV
Channel Separation	
Aux, Tape 5.1kΩ Shorted 1kHz	60dB
Tone Control Characteristics	
Bass boost/cut	±10dB (at 50Hz)
Treble boost/cut	±10dB (at 20kHz)
Bass Extension	+ 8dB (at 62Hz)
Filter Characteristics	
Low (Subsonic Builtin)	-15Hz, -12dB/oct
Continuous Loudness Control (Level-related equalization)	
Attenuation	-20dB (at 1kHz)
Rec Output Level/Impedance (Fixed)	
FM 100% mod 1kHz	500mV/5kΩ
FM 40kHz mod	380mV/5kΩ (G)
AM 30% mod 400Hz	150mV/5kΩ
FM SECTION	
Tuning Range	
	87.5 to 108.0MHz
50dB Quieting Sensitivity (IHF)	
Mono	1.6μV (15.3dBf)
Stereo	22μV (38.1dBf)

Usable Sensitivity	30dB Quieting 75Ω	0.8μV (9.3dBf)
Usable Sensitivity (DIN)	Mono (S/N 26dB)	0.8μV (9.3dBf) (G)(B)(A)
	Stereo (S/N 46dB)	25μV (39.2dBf) (G)(B)(A)
Image Response Ratio		50dB
IF Response Ratio		90dB
Spurious Response Ratio		70dB
AM Suppression Ratio		60dB
Capture Ratio		1.5dB
Alternate Channel Selectivity (IHF)		55dB
Selectivity (two signals)(DIN)		60dB (G)
Signal to Noise Ratio (IHF)		
	Mono	85dB
	Stereo	81dB
Signal to Noise Ratio (DIN-UNWeighted)		
	Mono	80dB (G)(B)(A)
	Stereo	76dB (G)(B)(A)
Harmonic Distortion		
	Mono 1kHz	0.1%
	Stereo 1kHz	0.15%
Harmonic Distortion (40kHz Dev)		
	Stereo 1kHz	0.15% (G)
Stereo Separation (IHF)		
	1kHz	40dB
Frequency Response		
	30Hz to 15kHz	+0.5dB
		-1.5dB
Sub-carrier Product Ratio (IHF)		
		45dB
AM Section		
Tuning Range		
	510 to 1620kHz (U)(C)	
	513 to 1620kHz (G)(A)(B)	
	510 to 1620kHz or	
	513 to 1620kHz (R)	
Usable Sensitivity		
		250μV
Selectivity		
		25dB
Signal to Noise Ratio		
		52dB
Image Response Ratio		
		40dB
Spurious Response Ratio		
		50dB
Harmonic Distortion (400Hz)		
		0.3%
GENERAL		
Power Supply		
	US & Canadian Models	120V AC, 60Hz
	General Model	110 - 120V AC/220 - 240V AC, 50/60Hz
	European Model	220V AC, 50Hz
	British & Australian Models	240V AC, 50Hz
Power Consumption		
		180W (U)(C)
		100W (R)
		250W (G)(A)(B)
AC Outlet		
	Switched	200W max.
	Unswitched	200W max.
Dimensions (W x H x D)		
		435 x 102 x 347.7mm (17-1/8 x 4 x 13-5/8)"
Weight		
		6.5kg (14.3 lbs)
(U) U.S.A. model		
(C) Canadian model		
(A) Australian model		
(G) European model		
(B) British model		
(R) General model		
<i>Specifications subject to change without notice.</i>		

PARTS LIST

REAR PANEL

U.S.A. & Canadian models

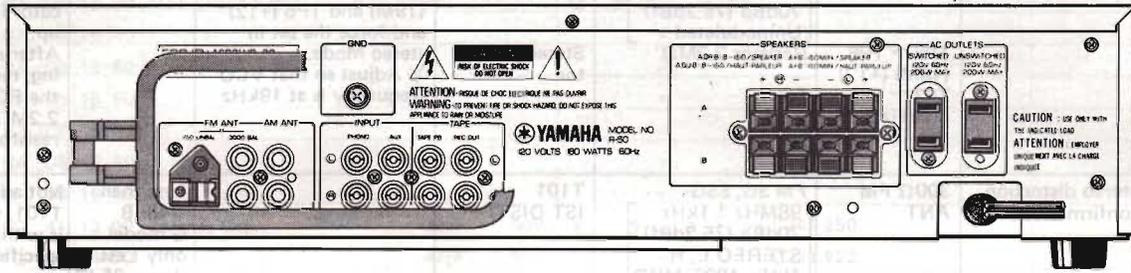

General model

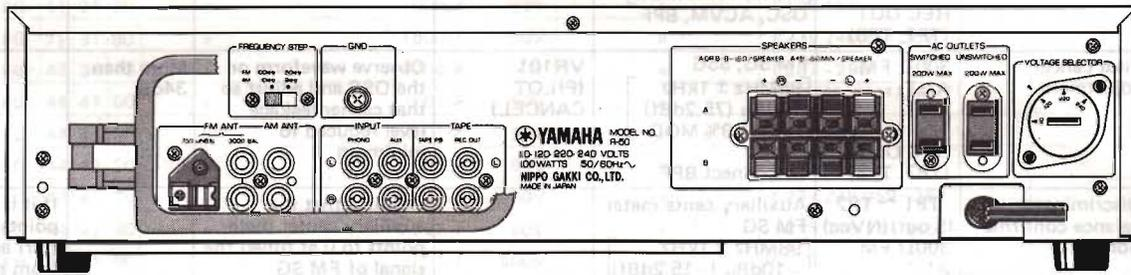

British & Australian models

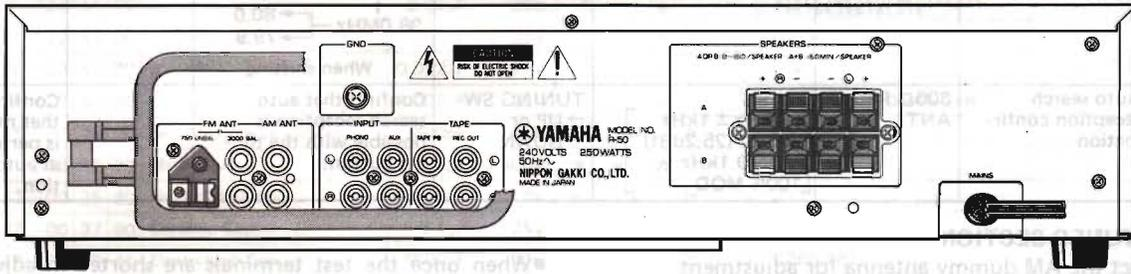

European model

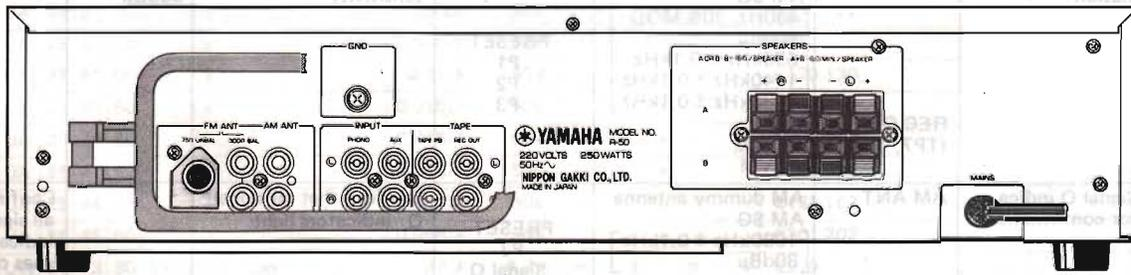

INTERNAL VIEW

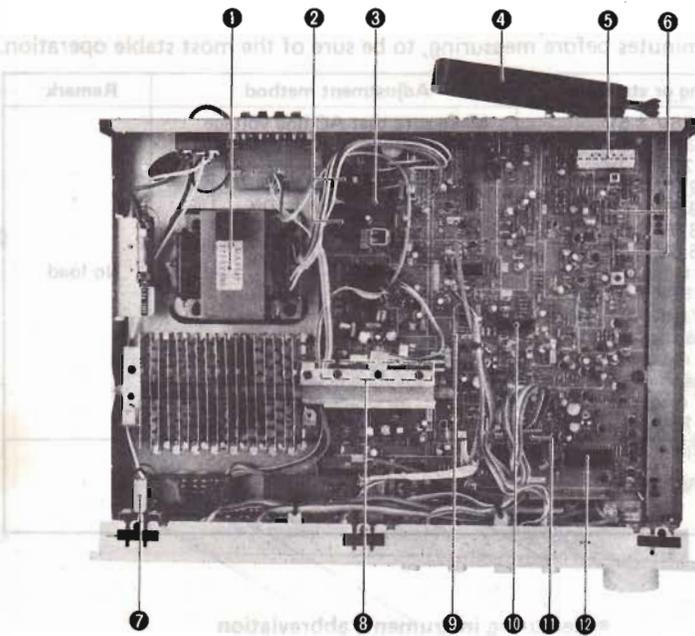

- ① POWER TRANSFORMER
 U.S.A. & Canadian models: GA66400
 European model: GA66410
 Australian & British models: GA66420
 General model: GA66430
- ② ELECTROLYTIC CAP.: 6800 μ F 46V
- ③ DIODE BRIDGE: S4VB20 or RB402 or 4D4B41
- ④ AM LOOP ANTENNA
- ⑤ FRONT END PACK
- ⑥ IF IC: μ PC577H (E, F)
- ⑦ POWER SWITCH
- ⑧ POWER IC: STK-4873
- ⑨ MAIN CIRCUIT BOARD (1)
- ⑩ MPX IC: LA3380
- ⑪ MICRO COMPUTER IC: LC6502C-604
- ⑫ TUNING CONTROLLER IC: LC7210

DISASSEMBLY PROCEDURES (Remove parts in order of disassembly as numbered.)

* Replacement of the parts of almost circuit boards in this unit is possible by removing the top and bottom cover.

- ① Removing Top Cover . . . Cup Screw 4x8 FNM3-3g
- ② Removing Front Panel . . . Binding Head Tapping
Screw 3x8 FCRM3-B ℓ
- ③ Removing Bottom Cover . . . Binding Head Tapping
Screw 3x8 FCRM3-B ℓ
- ④ Removing Heat Sink . . . Binding Head Tapping
Screw 3x8 FCM3-B ℓ

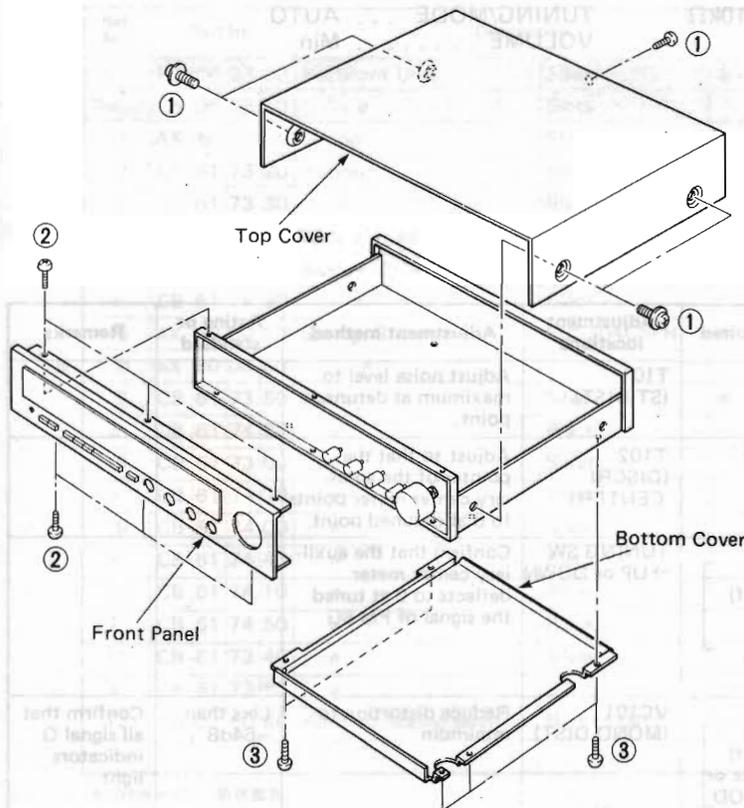

Fig. 1

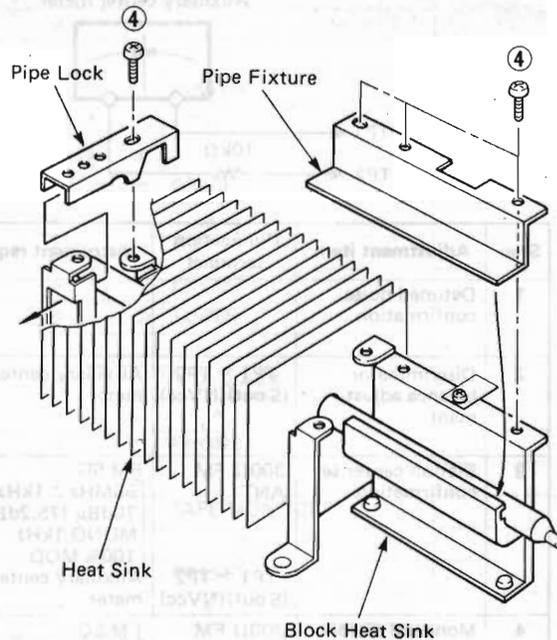

Fig. 2

ADJUSTMENTS

<CONFIRMATION OF AUDIO SECTION>

Before adjustment

Note 1: After the power switch is pushed on, wait for 5 minutes before measuring, to be sure of the most stable operation.

Step	Confirmation	Test point	Rating or standard	Adjustment method	Remark								
1	Power supply voltage	+B ~ E -B ~ E +20 ~ E +12 ~ E +9 ~ E -9 ~ E +5.6 ~ E FB ~ E AB ~ E	+36V ± 5V -36V ± 5V +20V ± 2V +12.5V ± 1V +9.5V ± 0.5V -8.9V ± 0.5V +5.6V ± 0.5V At FM reception mode +12V ± 1V At AM reception mode less than +1V At FM reception mode less than +1V At AM reception mode +12V ± 1V	Make sure that AC line voltage comes within <table border="1"> <thead> <tr> <th>Models</th> <th>AC line voltage</th> </tr> </thead> <tbody> <tr> <td>U, C</td> <td>120V ± 10%</td> </tr> <tr> <td>G</td> <td>220V ± 10%</td> </tr> <tr> <td>A, B</td> <td>240V ± 10%</td> </tr> </tbody> </table>	Models	AC line voltage	U, C	120V ± 10%	G	220V ± 10%	A, B	240V ± 10%	No load
Models	AC line voltage												
U, C	120V ± 10%												
G	220V ± 10%												
A, B	240V ± 10%												
2	DC offset	Speaker terminal or pin 5 of IC112 (L ch) and Pin 12 (R ch)	0V ± 50mV										

<TUNER ADJUSTMENT>

● Before adjustment

Note 1) After the Power switch is pushed on, wait for 5 minutes before measuring, to be sure of the most stable operation.

Note 2) Adjust the OSC coil and IFT with a nonferrous screw driver.

Note 3) Do not forget to keep the bottom cover on.

● Measuring instruments abbreviation

FM SG : FM signal generator

SSG : Stereo signal generator

AM SG : AM signal generator

OSC : Oscilloscope

DIST. M : Distortion meter

FC : Frequency counter

ACVM : AC volt meter

1. FM TUNER SECTION

● Use 200Hz to 15kHz bandpass filter to measure the REC OUT.

● On step 1 and 2 connect the auxiliary center meter (Ji00036 or similar) in series with the resistor 10kΩ between TP1 (S OUT) and TP2 (NVcc).

● Set the switches to the following positions.

INPUT TUNER

Band Select FM

TUNING/MODE ... AUTO

VOLUME Min

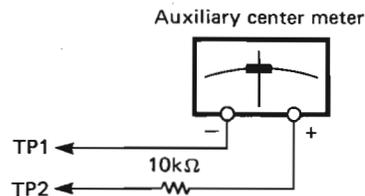

Step	Adjustment item	Connection terminal	Instrument required	Adjustment locations	Adjustment method	Rating or standard	Remarks
1	Detuned noise confirmation			T101 (ST DIST)	Adjust noise level to maximum at detuned point.		
2	Discriminator balance adjustment	TP1 ~ TP2 (S out) (NVcc)	Auxiliary center meter	T102 (DISCRI CENTER)	Adjust so that the pointer of the auxiliary center meter points to 0 at detuned point.		
3	Station center set confirmation	300Ω FM ANT TP1 ~ TP2 (S out) (NVcc)	FM SG 98MHz ± 1kHz 70dBμ (75.2dBf) MONO 1kHz 100% MOD Auxiliary center meter	TUNING SW → UP or DOWN	Confirm that the auxiliary center meter deflects to 0 at tuned the signal of FM SG		
4	Monaural distortion adjustment	300Ω FM ANT REC OUT (TP7, TP8)	FM SG 98MHz ± 1kHz 70dBμ (75.2dBf) monaural 100Hz or 400Hz 100% MOD DIST. M. OSC BPF	VC101 (MONO DIST)	Reduce distortion to minimum	Less than -64dB	Confirm that all signal Q indicators light

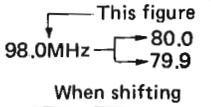
Step	Adjustment item	Connection terminal	Instrument required	Adjustment locations	Adjustment method	Rating or standard	Remarks
5	VCO adjustment	300Ω FM ANT TP5 ~ TP6 (19M) (+12) TP3 ~ TP4 (19kHz) (G)	FM SG 98MHz ± 1kHz 70dBμ (75.2dBf) Unmodulated Resistor 2.2MΩ FC	VR102 (VCO) Stereo indicator	① Connect resistor 2.2MΩ between TP5 (19M) and TP6 (+12) and force the set in stereo mode. ② Adjust so that VCO frequency is at 19kHz	19kHz ± 10Hz	Confirm that stereo indicator lights up. After adjusting, remove the FC and 2.2MΩ resistor.
6	Stereo distortion confirmation	300Ω FM ANT REC OUT (TP7, TP8)	FM SG, SSG 98MHz ± 1kHz 70dBμ (75.2dBf) STEREO L, R 1kHz, 100% MOD DIST. M, OSC BPF	T101 (ST DIST)		Less than -48dB G model only Less than -35dB	Not adjust T101, when it is within specifications.
7	Separation confirmation	300Ω FM ANT REC OUT (TP7, TP8)	FM SG, SSG 98MHz ± 1kHz 70dBμ (75.2dBf) STEREO L or R 1kHz, 100% MOD OSC, ACVM, BPF		Confirm that the leakage level of the opposite channel is minimum	Less than 26dB	
8	Pilot cancel adjustment	300Ω FM ANT REC OUT (TP7, TP8)	FM SG, SSG 98MHz ± 1kHz 70dBμ (75.2dBf) PILOT 9% MOD OSC Disconnect BPF	VR101 (PILOT CANCEL)	Observe waveform on the OSC and adjust so that carrier leakage level reduced to minimum	More than 34dB	
9	Discriminator balance confirmation	TP1 ~ TP2 (S out) (NVcc) 300Ω FM ANT	Auxiliary center meter FM SG 98MHz ± 1kHz -10dBμ (-15.2dBf)		Confirm that the auxiliary center meter points to 0 at tuned the signal of FM SG		If it is not points to 0, start all over from step 2.
10	If offset adjustment	300Ω FM ANT TEST terminals (K4, T6)	FM SG 98MHz ± 1kHz 70dBμ (75.2dBf) Short	VR103 (FM FINE)	By shorting TEST terminals, the counter shifts by one digit, then adjust so that the lowest effective digit comes to 9 or 0. 		After adjusting, open the TEST terminals.
11	Auto search reception confirmation	300Ω FM ANT	FM SG 98MHz ± 1kHz 20dBμ (25.2dBf) MONO 1kHz 100% MOD	TUNING SW → UP or DOWN	Confirm that auto search reception is possible with the tuning button.		Confirm that muting is performed at auto reception.

2. AM TUNER SECTION

● Connect the AM dummy antenna for adjustment.

● When once the test terminals are shorted in adjusting FM, the frequency of 630kHz, 1440kHz, and 1080 kHz is memoried at each AM preset position 1, 2 and 3.

Step	Adjustment item	Connection terminal	Instrument required	Adjustment locations	Adjustment method	Rating or standard	Remarks
1	Sensitivity confirmation	AM ANT REC OUT (TP7, TP8)	AM dummy antenna AM SG 400Hz, 30% MOD 50dBμ 630kHz ± 0.1kHz 1440kHz ± 0.1kHz 1080kHz ± 0.1kHz OSC. DST. M ACVM	PRESET P1 P2 P3	Confirm the maximum sensitivity	less than 55dBμ	
2	Signal Q indicator confirmation	AM ANT	AM dummy antenna AM SG 1080kHz ± 0.1kHz 80dBμ	PRESET P3 Signal Q	Confirm that all signal Q indicators light.		Confirm that all signal Q indicators goes out at detuned point.
3	Auto search reception confirmation	AM ANT	AM dummy antenna AM SG 1080kHz ± 0.1kHz 60dBμ	TUNING SW → UP or DOWN	Confirm that auto search reception is possible with the tuning button.		

3. DIGITAL CONTROL SECTION

Step	Adjustment item	Connection terminal	Instrument required	Adjustment locations	Adjustment method	Rating or standard	Remarks
1	Preset memory confirmation	300Ω FM ANT AM ANT	FM SG [98MHz ± 1kHz 70dBμ (75.2dBf) MONO 1kHz 100% MOD] AM dummy antenna AM SG [1080kHz ± 0.1kHz 80dBμ 400Hz, 30% MOD]	FM/AM SW TUNING SW MEMORY SW PRESET SW	① Memorizing the PRESET P1 at FM SG frequency. ② Memorizing the PRESET P2 at AM SG frequency. ③ Confirm that the frequency memorized is recalled.		① Press the FM button and tuned the 98MHz with AUTO seach ↓ Press the Memory button. ↓ The Memory indicator lights about 3 seconds ↓ Press the PRESET P1 during the Memory indicator lights. ↓ The PRESET LED of P1 lights. ② Press the AM button and tuned the 1080kHz with AUTO seach. ↓ Press the Memory button ↓ The Memory indicator lights and the PRESET LED of P1 flashes. ↓ Press the PRESET P2 ↓ The Memory indicator goes out and the PRESET LED of P2 lights.
2	Last channel memory confirmation			POWER SW	① Press the PRESET P1 ② Turn the power switch off. ③ After about 5 seconds, turn the power switch on. ④ Confirm that the PRESET P1 memorized is recalled.		④ The PRESET of P1 does not lights

•TEST POINT

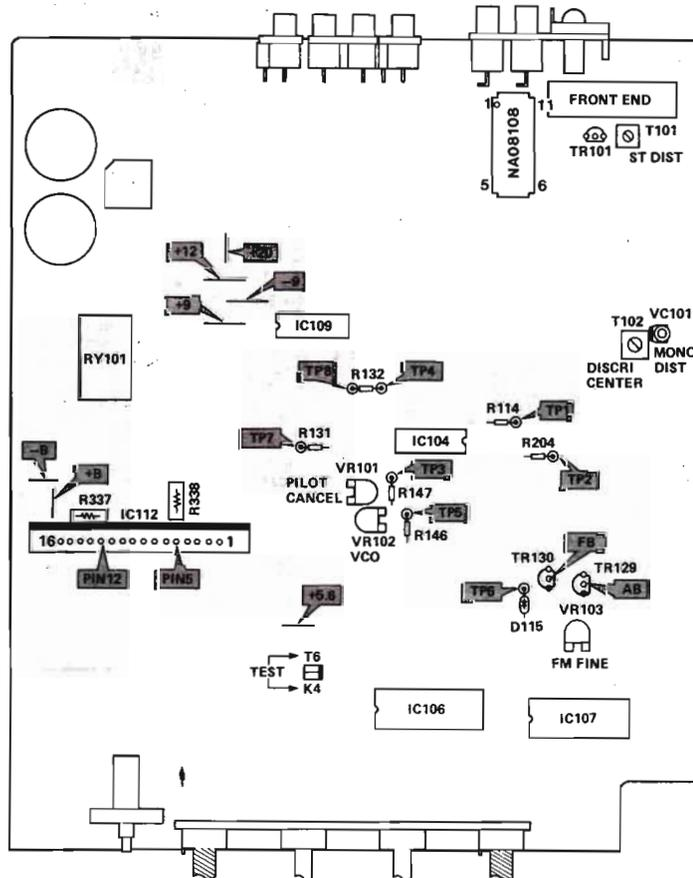

PRINTED CIRCUIT BOARD (Pattern side)

1 •Key circuit board

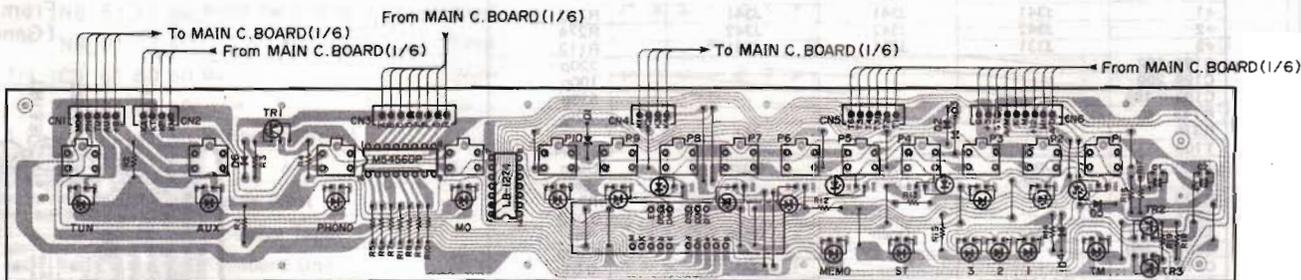

2 •Main circuit board (2/6 ~ 6/6)

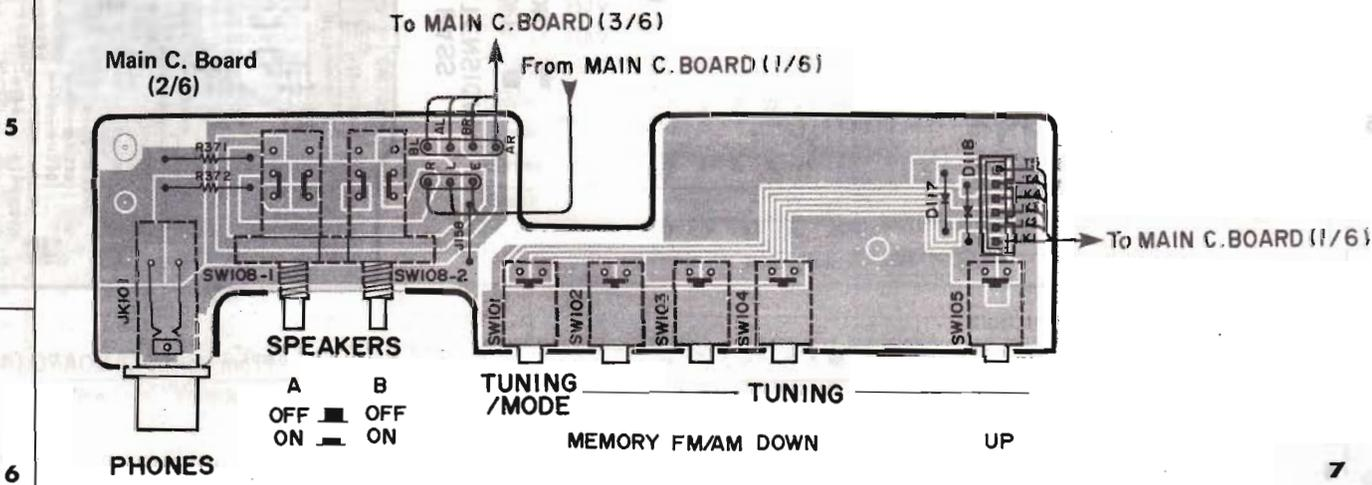
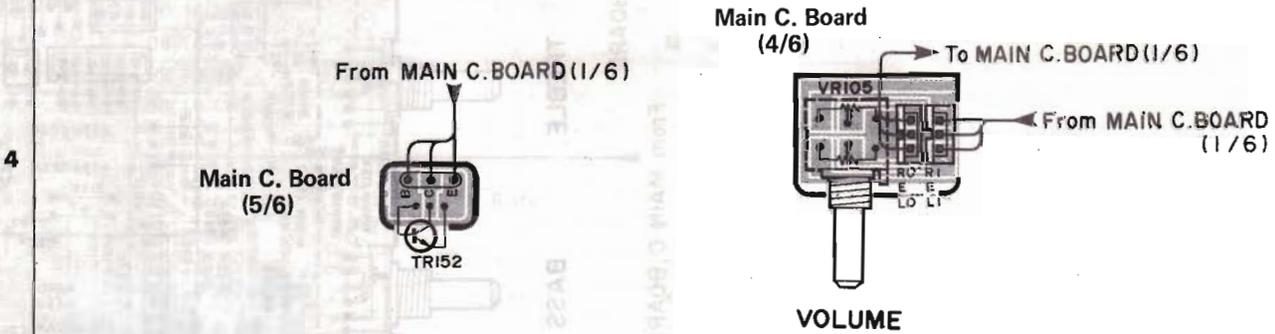
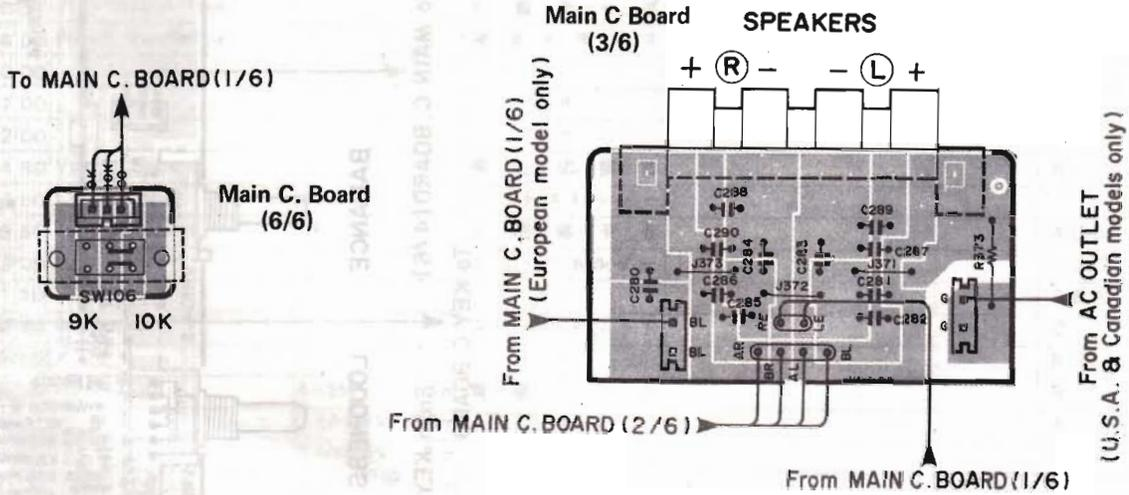

PRINTED CIRCUIT BOARD (Pattern side)

Main circuit board (1/6)

The following parts and values differ from each model, so refer to the corresponding column.

	R	U, C	A, B	G
#1	J341	J341	J341	R273
#2	J342	J342	J342	R274
#3	J331	J331	J331	R112
C191, 192				220p
C199, 200				100p
C193 ~ 196				330p
R113				12k
R375	15k	15k	15k	
T103				GE20043
J351	Open	Set	Open	Open
J361	Open	Open	Set	Set
R373				1/2P2.2M
C281 ~ 286				0.022
J371 ~ 373	Open	Open	Open	Set
C287 ~ 290				4700p
C219, 280				0.01
SW106	KA40094			
Main (6)	Set			

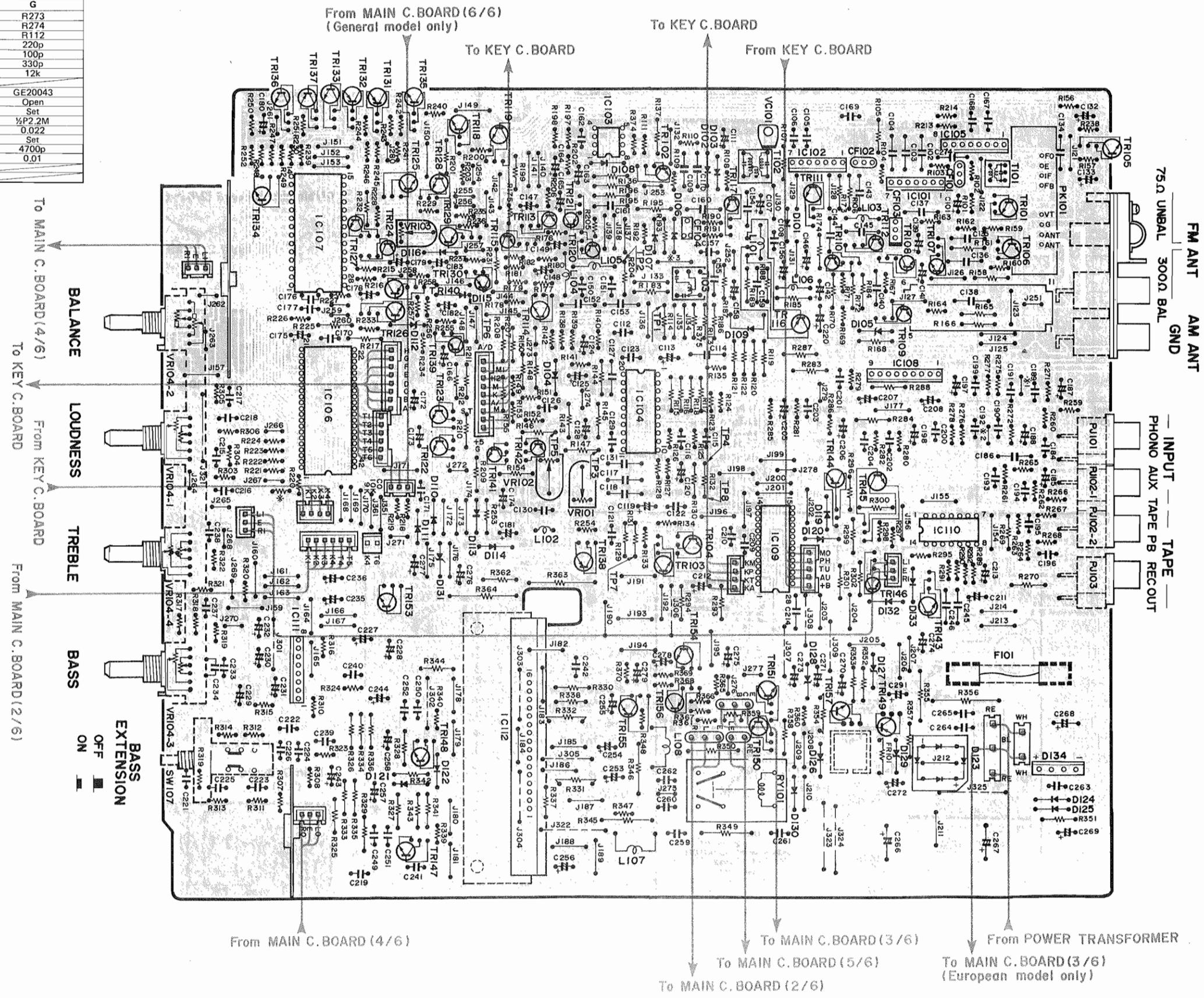

2

3

4

5

6

8

PARTS LIST

R-50

■WARNING

UL Standard 1270 requires that components marked Δ be replaced with parts having specifications equal to those originally installed.

● Carbon resistors of this receiver are $\frac{1}{4}W$. There is no description about them in this parts list. Use the "Part No." HJ350000 or equivalent.

■ ELECTRICAL PARTS

Ref. No.	Part No.	Description	部 品 名	Remarks	Common Model	Markets
※	NA 08 16 30	Main Circuit Board	Silver	総 合 シ ー ト		R
※	NA 08 16 40	"	"	"		U,C
※	NA 08 16 50	"	"	"		A
※	NA 08 16 60	"	"	"		G
※	NA 08 16 70	"	"	"		B
※	NA 08 16 80	"	Black	"		R
※	NA 08 16 90	"	"	"		G
	FG 41 13 90	Ceramic Cap	39pF 50V	セ ラ コ ン	C249,250	
	FG 41 14 70	"	47pF 50V	"	C221,222	
	FG 41 21 00	"	100pF 50V	"	C199,200	G
	FG 41 22 20	"	220pF 50V	"	C191,192	G
	FG 41 22 20	"	220pF 50V	"	C189,190,241,242	
	FG 41 23 30	"	330pF 50V	"	C193~196	G
	FG 41 25 60	"	560pF 50V	"	C217,218	
	FG 41 31 00	"	1000pF 50V	"	C108,168	
	FG 71 31 80	"	1800pF 50V	"	C239,240,251,252	
	FG 41 34 70	"	4700pF 50V	"	C287~290	G
	FG 44 41 00	"	0.01 μ F 50V	"	C106,108,157,187,189,171,184, 209,210,283	
	FG 44 41 00	"	0.01 μ F 50V	"	C219,280	G
	FG 44 42 20	"	0.022 μ F 50V	"	C281~286	G
	FG 44 44 70	"	0.047 μ F 50V	"	C237,238,259~262	
	FG 44 42 20	"	0.022 μ F 50V	"	C215,216,264,265	
	FH 23 41 00	"	0.01 μ F 500V	"	C186	
	Fi 19 12 20	"	22pF 50V	"	C176,177	
	Fi 19 21 00	"	100pF 50V	"	C109,110	
	FG 21 31 00	"	1000pF 50V	"	C143,152,160	
	FG 21 24 70	"	470pF 50V	"	C153	
	FG 21 34 70	"	4700pF 50V	"	C114,117,118	
	Fi 22 41 00	"	0.01 μ F 25V	"	C102~104,131,134~137,144, 145,154,159,161,214	
	Fi 22 41 00	"	0.01 μ F 25V	"	C155	G
	Fi 22 42 20	"	0.022 μ F 25V	"	"	R,U,A,C,B
	Fi 22 42 20	"	0.022 μ F 25V	"	C127,138,140,245,246	
	FS 25 26 80	Semi Conductive Ceramic Cap.	680pF 50V	S A コ ン	C126	
	FU 35 12 70	Mica Cap.	27pF 500V	マ イ カ コ ン	C170	
	FZ 00 35 80	Electrolytic Cap.	47000 μ F 5.5V	ケ ミ コ ン	C173	
※	FZ 00 37 90	Ceramic Cap.	0.1 μ F 25V	セ ラ コ ン	C233,234	
※	FZ 00 39 40	Electrolytic Cap.	6800 μ F 50V	ケ ミ コ ン	C266,267	
	UA 25 24 70	Mylar Cap.	470pF 50V	マ イ ラ ー コ ン	C115,116	A,G,B
	UA 25 26 80	"	680pF 50V	"	"	R,U,C
	UA 25 26 80	"	680pF 50V	"	C123	R,U,A,C,B
	UA 25 31 00	"	1000pF 50V	"	"	G
	UA 25 31 00	"	1000pF 50V	"	C121,122	
	UA 25 31 50	"	1500pF 50V	"	C112	
	UA 25 41 00	"	0.01 μ F 50V	"	C129,130	
	UA 25 41 50	"	0.015 μ F 50V	"	C150	
	UA 25 41 80	"	0.016 μ F 50V	"	C203,204	
	UA 25 41 80	"	0.018 μ F 50V	"	C223~226	
	UA 25 44 70	"	0.047 μ F 50V	"	C151,162	
	UA 25 45 80	"	0.056 μ F 50V	"	C201,202	
	UW 91 73 30	Electrolytic Cap.	33 μ F 6.3V	ケ ミ コ ン	C279	
	UW 91 74 70	"	47 μ F 6.3V	"	C181,142	
	UW 91 81 00	"	100 μ F 6.3V	"	C158,197,198	

※ New Parts (新規部品)

PARTS LIST
ELECTRICAL PARTS

WARNING
UL Standard 1370 requires that components marked "UL" be replaced with parts having specifications equal to those originally installed.
Carbon resistors of this resistor are 5W.
There is no description about them in this parts list.
Use the "Part No.", "M35" or equivalent.

Ref. No.	Part No.	Description	部 品 名	Remarks	Common Model	Markets
※	UW 91 82 20	Electrolytic Cap.	220 μ F 6.3V	ケ ミ コ ン	C111	
※	UW 81 84 70	"	470 μ F 6.3V	"	C174,179	
※	UW 82 74 70	"	47 μ F 10V	"	C278	
※	Ui 93 82 20	"	220 μ F 16V	"	C183,207,220	
	UW 93 71 00	"	10 μ F 16V	"	C101,107,113,124,139,146,156,165,172	
	UW 93 73 30	"	33 μ F 16V	"	C141,166,180,275	
	UW 93 74 70	"	47 μ F 16V	"	C182	
	UW 94 74 70	"	47 μ F 25V	"	C276	
	UW 94 93 30	"	3300 μ F 25V	"	C268	
	UW 85 72 20	"	22 μ F 35V	"	C243,244	
	UW 86 52 20	"	0.22 μ F 50V	"	C185,213	
	UW 96 54 70	"	0.47 μ F 50V	"	C148,163,164,175	
	UW 96 61 00	"	1 μ F 50V	"	C119,120,125,126,132,149,187,188,212,269,271,274,277	
	UW 96 62 20	"	2.2 μ F 50V	"	C133	
	UW 96 63 30	"	3.3 μ F 50V	"	C147,178	
	UW 96 64 70	"	4.7 μ F 50V	"	C205,206,211,231,232,235,236	
	UW 96 71 00	"	10 μ F 50V	"	C208,227-230,256,272,273,291	
	UW 96 72 20	"	22 μ F 50V	"	C270,254	
	UW 96 74 70	"	47 μ F 50V	"	C255,257,258	
	UW 86 81 00	"	100 μ F 50V	"	C253	
	FY 00 01 90	Trimmer Cap.	5P	ト リ マ ー コ ン	VC101	
	GD 90 03 40	Output Coil	1.5 μ H	ア ウ ト ブ ッ ト コ イ ル	L107,108	
	GE 30 04 50	Inductor	1mH	イ ン ダ ク タ ー	L104,105	
	GE 30 05 00	"	12 μ H	"	L103,106	
	GE 30 05 10	"	120 μ H	"	L101	
	GE 90 06 90	"	8.2mH	"	L102	
	GE 10 02 80	FM Discriminator Coil	GE10028	F M デ ィ ス ク リ コ イ ル	T102	
	GE 10 06 50	FM IFT	GE10065	F M I F T	T101	
	GE 20 04 30	Anti-birdie Filter	114kHz	ア ン チ バ ー デ ィ ー フ ィ ル タ ー	T103	G
	GG 00 04 20	AM Ceramic Discriminator	CDA450A	A M セ ラ ミ ッ ク デ ィ ス ク リ	CF104	
※	GG 00 06 20	FM Ceramic Filter	SFE10 7MS 3GHY-Z	F M セ ラ ミ ッ ク フ ィ ル タ ー	CF101,102	G
※	GG 00 06 30	"	SFE10 7 MMH-Z	"	"	R,U,A,C,B
※	GG 00 06 60	AM Ceramic Filter	SFU-450B9	A M セ ラ ミ ッ ク フ ィ ル タ ー	CF103	
※	HF 85 42 20	Carbon Resistor	22 Ω 1/6 W	カ ー ボ ン 抵 抗	R127,128	
※	HF 85 51 00	"	100 Ω "	"	R135,160,191	
※	HF 85 51 20	"	120 Ω "	"	R277,278	
※	HF 85 51 50	"	150 Ω "	"	R103,	
※	HF 85 51 50	"	150 Ω "	"	R271,272	R,U,A,C,B
※	HF 85 61 50	"	1.5k Ω "	"	"	G
※	HF 85 52 20	"	220 Ω "	"	R108,176,258,361	
※	HF 85 53 30	"	330 Ω "	"	R104,321,322	
※	HF 85 54 70	"	470 Ω "	"	R290,307,308	
※	HF 85 55 60	"	560 Ω "	"	R265~268	R,U,A,C,B
※	HF 85 62 20	"	2.2k Ω "	"	"	G
※	HF 85 61 00	"	1k Ω "	"	R102,141,179,250,370	
※	HF 85 61 20	"	1.2k Ω "	"	R139,252	
※	HF 85 61 20	"	1.2k Ω "	"	R273,274	G

※ New Parts (新規部品)

Ref. No.	Part No.	Description	部 品 名	Remarks	Common Model	Markets
* HF	85 61 50	Carbon Resistor	1.5kΩ 1/6W	カーボン抵抗	R171	
* HF	85 61 80	"	1.8kΩ "	"	R297,298	
* HF	85 62 20	"	2.2kΩ "	"	R244,247,339,340	
* HF	85 63 30	"	3.3kΩ "	"	R167,175,235,255,257	
* HF	85 63 90	"	3.9kΩ "	"	R317~320	
* HF	85 64 70	"	4.7kΩ "	"	R101,133,134,156,177,241,281,282	
* HF	85 66 80	"	6.8kΩ "	"	R109,110,178	
* HF	85 68 20	"	8.2kΩ "	"	R181	
* HF	85 71 00	"	10kΩ "	"	R123,124,162,163,169,192,202,205,215,216,236,237,242,256,303,304,359,368	
* HF	85 71 50	"	15kΩ "	"	R111,203	
* HF	85 72 20	"	22kΩ "	"	R140,213,214,228,233,275,276,289	
* HF	85 72 70	"	27kΩ "	"	R164,249,311,312	
* HF	85 73 30	"	33kΩ "	"	R142,230,243	
* HF	85 73 90	"	39kΩ "	"	R246,366	
* HF	85 74 70	"	47kΩ "	"	R157,229,234,305,306	
* HF	85 75 60	"	56kΩ "	"	R259,260,279,280	
* HF	85 76 80	"	68kΩ "	"	R180	
* HF	85 78 20	"	82kΩ "	"	R369,292	
* HF	85 81 00	"	100kΩ "	"	R125,126,151,182,198,200,218~224,239,240,254,285,286,323,324,347,348,365	
* HF	85 81 80	"	180kΩ "	"	R360	
* HF	85 82 20	"	220kΩ "	"	R138,149,152,153,226,238	
* HF	85 83 30	"	330kΩ "	"	R227,245,248,291,313,314	
* HF	85 84 70	"	470kΩ "	"	R159,190,206,295,367	
* HF	85 88 20	"	820kΩ "	"	R309,310	
* HF	85 91 00	"	1MΩ "	"	R197,251,261~264,315,316	
HG	30 92 20	"	2.2MΩ RD50S	"	R373	U.C
HL	71 34 70	Metal Oxide Film Resistor	4.7Ω 1P	酸化金抵抗	R345,346,349,350	
HL	71 51 50	"	150Ω 1P	"	R355	
HL	71 52 20	"	220Ω 1P	"	R371,372	
HL	72 45 60	"	56Ω 2P	"	R363,364	
HL	33 53 90	"	390Ω 3P	"	R356	
HU	57 81 00	Metal Film Resistor	100 kΩ	金属被膜抵抗	R217	
HV	35 42 20	Flame Proof Carbon Resistor	22Ω RDF25SF	不燃化カーボン抵抗	R332	
HV	35 51 00	"	100Ω "	"	R331	
HV	35 48 20	"	82Ω "	"	R354	
HZ	00 29 20	Metal Plate Resistor	0.47Ω 3P	金属板抵抗	R337,338	
HT	37 00 50	Semi Variable Resistor	B5kΩ	半固定抵抗	VR103	} Interchangeable
HT	57 05 70	"	B5kΩ	"	"	
HT	37 00 20	"	B10kΩ	"	VR102	} Interchangeable
HT	57 05 80	"	B10kΩ	"	"	
HT	37 00 30	"	B100kΩ	"	VR101	
HS	41 18 40	VR Unit		V R ユ ニ ッ ト	VR104	
HS	41 18 50	Variable Resistor		可変抵抗器	VR105	
HW	39 41 00	Fuse Resistor	10Ω 1/4W	ヒューズ抵抗	FR101	
iA	09 70 00	Transistor	2SA970 (GR,BL)	トランジスタ	TR116	} Inter-changeable
iA	09 99 10	"	2SA999 (E,F)	"	TR110,113,120,121,124,127,129,130~132,137~140,144,156,158	
iA	11 27 00	"	2SA1127(R,S,T)	"	"	
iA	12 62 00	"	2SA1262(O,Y,G)	"	TR149	
iB	08 34 00	"	2SB834	"	"	

* New Parts (新規部品)

Ref. No.	Part No.	Description	部 品 名	Remarks	Common Model	Markets
*	iC 19 23 00	Transistor	2SC1923	ト ラ ン ジ ス タ	TR111	
	iC 20 88 00	"	2SC2088(BL,V)	"	TR147,148	
	iC 22 40 00	"	2SC2240(GR,BL)	"	"	
	iC 23 20 10	"	2SC2320(E,F)	"	TR101,102,106-108,112,114,115,117-119,122,123,125,126,128,133-138,141-143,150,151,154	} Inter-changeable
	iC 26 34 00	"	2SC2634(R,S,T)	"	"	
*	iC 28 78 00	"	2SC2878	"	TR145,146	
*	iD 13 02 00	"	2SD1302(R,S)	"	"	
	iD 06 55 00	"	2SD655 (D,E,F)	"	TR103,104,109	
*	iD 10 12 00	"	2SD1012(G,H)	"	"	} Interchangeable
	iD 13 02 00	"	2SD1302(R,S)	"	"	
	iD 04 00 20	"	2SD400(F)	"	TR152,153	
*	iD 09 72 00	"	2SD972	"	TR157	
*	iD 06 35 00	"	2SD635	"	"	
	iF 00 00 40	Diode	1S1555	ダ イ オ ー ド	D102,103	
	iF 00 00 40	"	1S1555	"	D101,104,106-111,113-122,124-126,130,132,133	} Inter-changeable
	iF 00 06 70	"	1S2473	"	"	
	iF 00 18 40	Zener Diode	RD3.0EB2	ツェナーダイオード	D105,112	
	iF 00 33 20	"	HZ9C-3	"	D128,129	
	iF 00 16 70	"	RD6.8EB2	"	D131	
*	iF 00 44 30	"	HZ12C2	"	D127	
	iH 00 08 10	Diode Bridge	1B4B41	ダイオードブリッジ	D134	
	iH 00 08 70	"	4D4B41	"	D123	} Interchangeable
	iH 00 10 40	"	RB402(LFD)	"	"	
	iH 00 10 90	"	S4VB20	"	"	
	iG 00 12 70	IC	TC4066BP	I C	IC110	} Interchangeable
*	iG 08 92 00	"	LC4066B	"	"	
	iG 00 13 90	"	NJM4558DV	"	IC103	
	iG 02 92 20	"	LA3380	"	IC104	
	iG 03 45 00	"	μPC577H(E,F)	"	IC101,102	
	iG 04 14 00	"	M54459L	"	IC105	
	iG 04 91 00	"	LC7210	"	IC107	
	iG 08 01 00	"	LC7815	"	IC109	
*	iG 08 53 00	"	LC6502C-604	"	IC106	
*	iG 08 89 00	"	STK-4873	"	IC112	
*	iG 09 21 00	"	M5219L	"	IC111	
*	iG 08 52 00	"	AN8557	"	IC108	} Interchangeable
*	iG 08 29 00	"	NJM2043SD	"	"	
	KA 40 09 40	Slide Switch	SSB-022	ス ラ イ ド ス イ ッ チ	SW106	R
	KA 80 28 20	Push Switch	2circuit2point	プ ッ シ ュ ス イ ッ チ	SW107	
*	KA 80 37 40	"	"	"	SW108	
	KA 90 29 30	Switch		タ ク ト ス イ ッ チ	SW101~105	
	KB 00 03 50	Fuse	T2.0A 250V	ヒ ュ ー ズ	F101	R
	KB 00 16 60	"	T1.6A 250V	"	"	A,G,B
	KB 00 10 30	"	2.0A 250V	"	"	U,C
	KC 00 11 00	Relay	DC12V	リ レ -	RY101	R,A,G,B
	KC 00 14 90	"	"	"	"	U,C
*	LB 20 22 90	Pin Jack	2P	ピ ン ジャ ッ ク	PJ101,103	

* New Parts (新規部品)

△

TECHNICAL PARTS (All-over)

Ref. No.	Part No.	Description	部 品 名	Remarks	Common Model	Markets
	LB 40 10 30	Pin Jack	4P	ピンジャック	PJ102	K-1000
	LB 30 17 50	Headphone Jack	Gray	ヘッドホンジャック	JK101	A-500 R,U,A,G,C,B
	LB 30 17 60	"	Black	"	"	R,G
※	PA 00 07 50	Front End Pack	FE529U12	フロントエンドパック	PK101	
※	QU 00 39 00	Quartz Crystal Unit	32kHz	水 晶 振 動 子		
	LA 00 39 90	Antenna Terminal	5P	アンテナ端子板		R,U,A,C
	LA 00 40 00	"	5P	"		G,B
※	LA 00 42 50	Speaker Terminal		スピーカーターミナル		R,A,B
※	LA 00 43 30	"		"		U,G,C
	LA 00 21 10	Wrapping Terminal	P=5 2P i-Type	i 型ラッピング端子板		U,G,C
	LA 00 20 00	"	P=7.5 2P i-Type	"		
	LA 00 23 20	"	P=7.5 3P i-Type	"		R,U,A,C,B
	LA 00 25 70	"	P=7.5(0) 3P i-Type	"		G
	LB 20 13 90	2.5 Pitch Base Pin	TEB2P-SHF	2.5 ピッチベースピン		
	LB 20 18 80	Fuse Holder Pin	PC-FH1	ヒューズホルダーピン		
※	LB 92 10 40	Connector Plug	4P(i-Type)	コネクタプラグ		
※	LB 92 10 50	"	5P(i-Type)	"		
※	LB 92 10 60	"	6P(i-Type)	"		
※	LB 92 10 80	"	8P(i-Type)	"		
※	LB 92 10 90	"	9P(i-Type)	"		
※	NA 08 10 80	AM Coil Pack		A M コイルパック		
※	AA 61 70 10	Sealed Plate	40×30	シールド板		
※	AA 61 69 90	"	60×30	"		
	BA 08 40 00	Radiator		放 熱 器		K-1000
	BA 08 57 50	Radiation Block		放 熱 ブ ロ ッ ク		R-30
	BB 06 83 70	Ground Plate		ア ー ス 金 具		
	CB 06 88 80	Plastic Rivet		プラスチックリベット		
		Binding Head Tapping Screw	3×8 FCM3-B 1	バインドタッピングネジ		
		"	3×14 FCM3-B 1	"		
	CB 06 92 50	Binding Tie	BK-1	インシュロックタイ		

※ New Parts (新規部品)

MECHANISM PARTS (All-over)

Ref. No.	Part No.	Description	部 品 名	Remarks	Common Model	Markets
* 1	NB 61 17 30	Front Panel Unit	Silver	パネルユニット		
* "	NB 61 17 40	"	Black	"		R.G
* 1-1	CB 61 80 80	Button	Silver	シーソーボタン	R-30	
* "	CB 61 80 90	"	Black	"	"	R.G
* 1-2	CB 61 81 40	Button (3 Range)	Silver	3 連 ボ タ ン		
* "	CB 61 81 50	"	Black	"		R.G
1-3	CB 06 88 80	Plastic Rivet		プラスチックリベット		
1-4	CB 07 41 90	Adhesive Tape		ダブルタックテープ		
* 1-5	PB 06 28 00	Keyboard Unit	Silver	キーボードユニット		
* "	PB 06 28 10	"	Black	"		R.G
1-6	ED 03 00 66	Binding Head Screw	3×6 ZMC2-Y	バインド小ネジ		
1-7	CB 08 50 50	Antivibration Tape		防振テープ		
* 2	GA 66 43 00	Power Transformer		電源トランス		R
* "	GA 66 40 00	"		"		U.C
* "	GA 66 41 00	"		"		G
* "	GA 66 42 00	"		"		A.B
3	LB 20 14 80	Voltage Selector		電圧切換器		R
4	CB 07 27 50	Cord Stopper	SR-4N-4	コードストッパー		
5	LA 00 29 50	Terminal Board	2P	中継端子台		A.G.B
6	LB 20 13 00	Fuse Holder		ヒューズホルダー		R.U.C
"	LB 20 21 10	"		"		G.B.A
7	LB 40 09 40	AC Outlet		A C アウトレット		C
"	LB 40 10 00	"		"		R.U
8	MG 00 07 80	Power Cord	6 A 250V 2 m	電源コード		R
"	MG 00 09 20	"	7.5 A 250V 2.5m	"		A
"	MG 00 09 50	"	2.5 A 250V 2 m	"		G
"	MG 00 10 00	"	6 A 300/500V 2 m	"		B
"	MG 00 14 50	"	10A 125V 1.98m	"	} Inter } Changeable	U.C
"	MG 00 14 60	"	10A 125V 2 m	"		U.C
* 9	NA 08 16 30	Main Circuit Board	Silver	総合シート		R
* "	NA 08 16 40	"	"	"		U.C
* "	NA 08 16 50	"	"	"		A
* "	NA 08 16 60	"	"	"		G
* "	NA 08 16 70	"	"	"		B
* "	NA 08 16 80	"	Black	"		R
* "	NA 08 16 90	"	"	"		G
10	KA 80 36 10	Push Switch	TV-3	プッシュスイッチ	POWER	
11	Fi 38 41 00	Ceramic Cap.	0.01μ F	セラコン		
12	CB 09 52 60	Cover		コンデンサーカバー		
13	CB 09 95 80	Fuse Holder Cover		ヒューズホルダーカバー		U
14	KB 00 03 50	Fuse	T 2 A 250V	ヒューズ		R
"	KB 00 16 60	"	T 1.6 A 250V	"		G.B.A
"	KB 00 25 70	"	4.0 A 250V	"		U.C
15	KB 00 03 80	"	T 4.0 A 250V	"		R
* 16	AA 61 53 90	Top Cover	Silver	トップカバー	R-30	
* "	AA 61 54 00	"	Black	"	"	R.G
* 17	AA 61 63 40	Bottom Cover	Silver	ボトムカバー	"	
* "	AA 61 76 90	"	Black	"		R.G
* 18	AA 61 64 00	Rear Panel		リアパネル		R
* "	AA 61 64 10	"		"		U.C
* "	AA 61 64 20	"		"		G
* "	AA 61 64 30	"		"		A.B
* 19	AA 61 64 50	Plate		B-E X シールド板		

* New Parts (新規部品)

EXP. DEPT. VIEW (Key) Unit

Ref. No.	Part No.	Description	部 品 名		Remarks	Common Model	Markets
* 20	BA 08:57:40	Heat Sink	35W		ヒートキッカー		
21	BA 08:48:90	Knob	Silver		ツマミ	VOLUME	A-500
"	BA 08:50:90	"	Black		"	"	R.G
22	BA 08:39:50	"	Silver		"	BASS, TREBLE, BALANCE	A-05
"	BA 08:58:70	"	Black		"	"	R.G
23	BA 08:44:90	"	Silver		"	LOUDNESS	"
"	BA 08:45:00	"	Black		"	"	R.G
24	CB 61:01:30	Push Button	Silver		プッシュボタン	SPEKERS, BASS, EXTENTION	K-200
"	CB 61:01:40	"	Black		"	"	R.G
25	CB 61:03:90	Leg			脚		"
* 26	CB 61:90:20	Rubber, Antivibration			防振ゴム		
27	CB 08:17:00	Clip			クリップ		CR-420
28	CB 60:74:70	Antenna Holder			アンテナホルダー		T-960II
29	ED 33:00:66	Binding Head Screw	M3X6	FCM3-BL	バインド小ネジ	PACK	
30	ED 32:60:46	"	M2.6X4	FCM3-BL	"	PACK	R
31	Ei 33:00:86	Binding Head Tapping Screw	3X8	FCRM3-BL	バインドタッピングネジ	PACK	
32	Ei 33:01:06	"	3X10	ZMC2-BL	"	PACK	
33	ED 34:00:66	Cup Screw	4X6	FCM3-BL	カップスクリュー(Sタイト)		
34	EZ 00:13:10	"	4X8	FNM3-3g	カップタイトネジ	Silver	
"	EZ 00:13:20	"	4X8	FCM3-BL	"	Black	R.G
35	EZ 00:14:00	Ground Terminal Screw	3X13.5	MFNI-II	アース端子ネジ		
36	EV 90:13:60	Sens Plain Washer	φ10×φ8.6×±0.8	FNM3-3g	セムス平座金		
37	EV 20:31:06	Plain Washer	φ10	FMC2-BL	平座金	PACK	
38	CB 06:88:80	Plastic Rivet			プラスチックリベット		
39	EZ 00:13:50	Cup Screw	3X14	FCM3-BL	カップスクリュー(Bタイト)		
40	Ei 33:00:86	Bind Bonding Head Taping Screw	3X8	FCM3-B	バインドボンディングタッピングネジ	PACK	
* 41	AA 61:64:60	Holder, Pipe			パイプ押え		
* 42	AA 61:64:70	Pipe Lock			パイプロック		
* 43	AA 61:64:80	Unit Base Fixture	A		ユニットベース押え		
* 44	AA 61:64:90	"	B		"		
* 45	AA 61:63:20	Holder, Trans former			トランスホルダー		
46	EV 41:30:36	Washer	φ3		ワッシャー	PACK	
	CB 06:92:50	Binding Tie	BK-1		インシュロックタイ		
		Accessories Assembly			付属品 Ass'y		
	Mi 08:28:50	Antenna	FM		FMQマッチアンテナ		
* Mi 08:29:10	Loop Antenna	AM			ループアンテナ		

* New Parts (新規部品)

EXPLODED VIEW (Keyboard Unit)

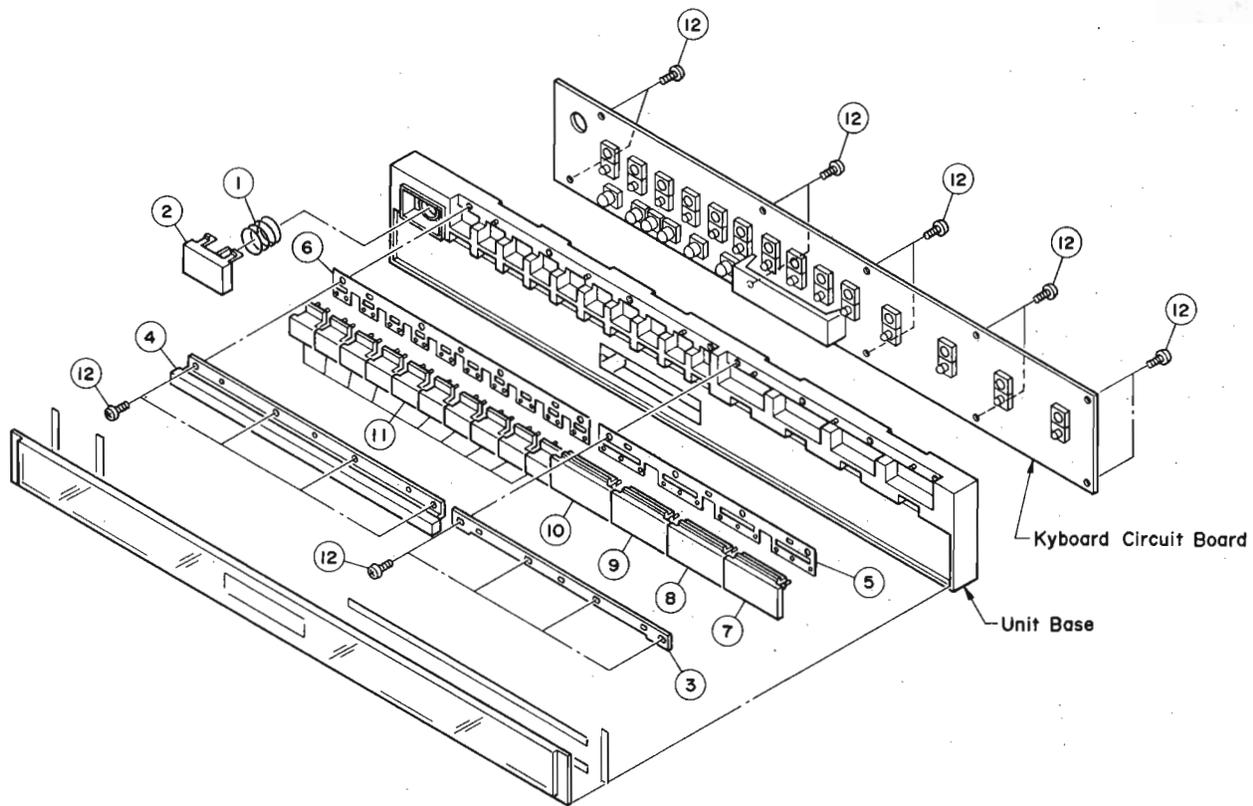

MECHANISM PARTS (Keyboard Unit)

Ref. No.	Part No.	Description	部 品 名	Remarks	Common Model	Markets
*	PB 06 28 00	Keyboard Unit	Silver	キーボードユニット		
*	PB 06 28 10	"	Black	"		R, G
*	1 AX 60 00 40	Spring	SUS304WPB	ス プ リ ン グ		
*	2 CB 61 73 20	Button	Silver	ボ タ ン	POWER	
*	" CB 61 73 30	"	Black	"	"	
*	3 AX 60 00 70	Spring, Hold	t 1.6	バ ネ 押 え		
*	4 CB 61 75 00	Button Blow	Silver	ボ タ ン ブ ロ ウ	PRESET	
*	" CB 61 75 30	"	Black	"	"	
*	5 AX 60 00 50	Spring, Button	SUS304CSPH	ボ タ ン バ ネ	INPUT	
*	6 AX 60 00 60	"		"	PRESET	
*	7 CB 61 73 80	Button	Silver	ボ タ ン	TUNER	
*	" CB 61 74 20	"	Black	"	"	
*	8 CB 61 73 90	"	Silver	"	VIDEO/AUX	
*	" CB 61 74 30	"	Black	"	"	
*	9 CB 61 74 00	"	Silver	"	PHONO	
*	" CB 61 74 40	"	Black	"	"	
*	10 CB 61 74 10	"	Silver	"	TAPE MONITOR	
*	" CB 61 74 50	"	Black	"	"	
*	11 CB 61 73 40	"	Silver	"	PRESET	
*	" CB 61 73 50	"	Black	"	"	
*	12 EA 02 60 66	Pan Head Tapping Screw	M2.6x6 ZMC2-Y	ナベタッピングネジ		

* New Parts (新規部品)

R-50

YAMAHA

SPECIFICATIONS

ITEM NO.	DESCRIPTION	QTY	UNIT	REMARKS
1
2
3
4
5
6
7
8
9
10
11
12
13
14
15
16
17
18
19
20
21
22
23
24
25
26
27
28
29
30
31
32
33
34
35
36
37
38
39
40
41
42
43
44
45
46
47
48
49
50
51
52
53
54
55
56
57
58
59
60
61
62
63
64
65
66
67
68
69
70
71
72
73
74
75
76
77
78
79
80
81
82
83
84
85
86
87
88
89
90
91
92
93
94
95
96
97
98
99
100

120V AC 50Hz
 240V AC 50Hz
 220V AC 60Hz

